



TITAN®

OPERATION MANUAL

POWRLINER™ 4500

PERMASTROKE TECHNOLOGY™

Hydraulic Fluid Displacement Pump System Inside

AIRLESS, HIGH-PRESSURE SPRAYING UNIT

- EN - OPERATION MANUAL 2

MODEL 2407312

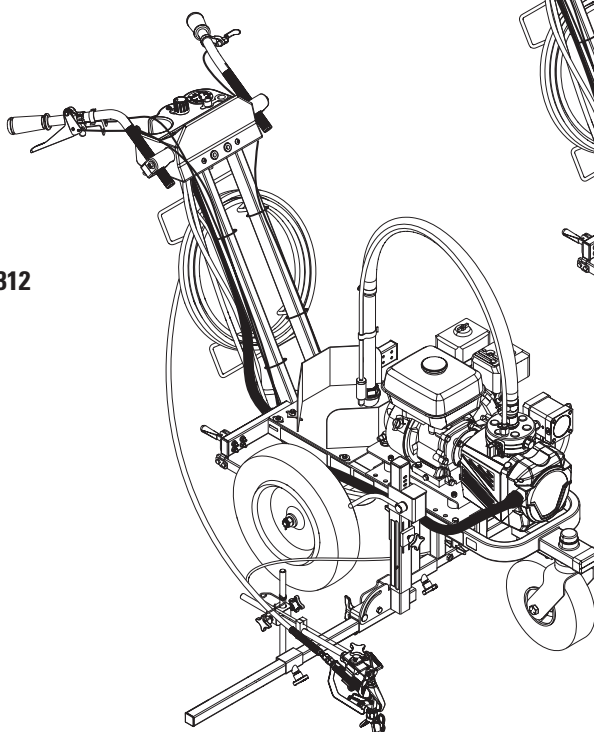

MODEL 2407313

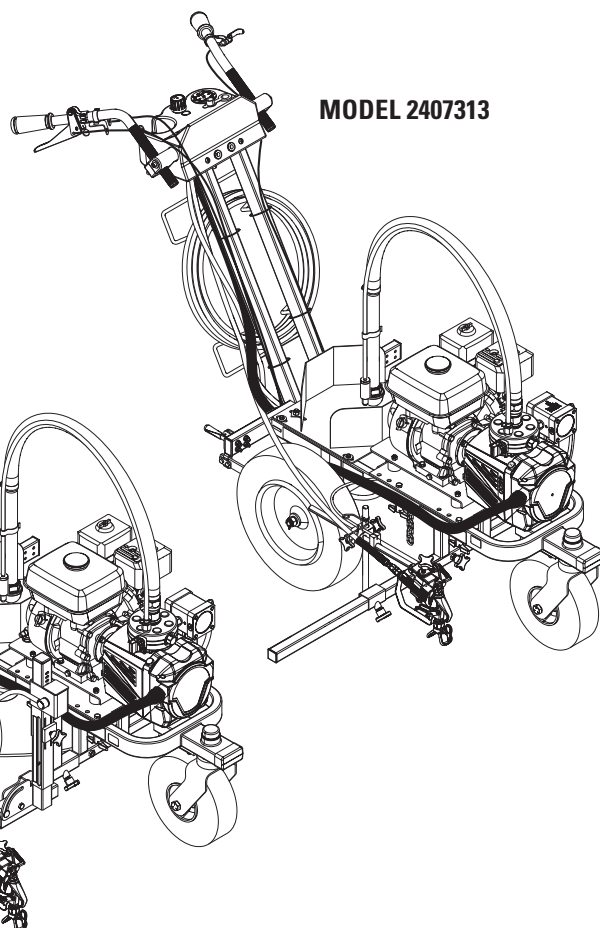

Warning!

Attention: Danger of injury by injection!
Airless units develop extremely high spraying pressures.

**1**

Never put your fingers, hands or any other parts of the body into the spray jet!

**Never point the spray gun at yourself, other persons or animals.
Never use the spray gun without safety guard.**

Do not treat a spraying injury as a harmless cut. In case of injury to the skin through coating materials or solvents, consult a doctor immediately for quick and expert treatment. Inform the doctor about the coating material or solvent used.

2

The operating instructions state that the following points must always be observed before starting up:

1. Faulty units must not be used.
2. Secure Titan spray gun using the trigger lock on the trigger.
3. Ensure that the unit is properly earthed.
4. Check allowable operating pressure of high-pressure hose and spray gun.
5. Check all connections for leaks.

3

The instructions regarding regular cleaning and maintenance of the unit must be strictly observed.

Before any work is done on the unit or for every break in work the following rules must be observed:

1. Release the pressure from spray gun and hose.
2. Secure the Titan spray gun using the trigger lock on the trigger.
3. Switch off unit.

Be safety conscious!

1	SAFETY REGULATIONS FOR AIRLESS SPRAYING	4	6	CLEANUP	20
1.1	Explanation of symbols used	4	6.1	Special cleanup instructions for use with flammable solvents	20
1.2	Safety hazards	4	6.2	Cleaning the sprayer	20
1.3	Gasoline engine safety	6	6.3	Cleaning the unit from outside	20
1.4	Fueling (gas engine)	7	6.4	Suction filter	21
2	MAIN AREAS OF APPLICATION	8	6.5	Cleaning the high-pressure filter	21
2.1	Application	8	6.6	Cleaning the airless spray gun	22
2.2	Coating materials	8	7	SERVICING	22
2.3	Glass bead dispenser kits (sold separately)	8	7.1	General servicing	22
3	DESCRIPTION OF UNIT	9	7.2	High pressure hose	22
3.1	Airless process	9	7.3	Basic engine maintenance	23
3.2	Instruction manuals list	9	7.4	Typical wear parts	23
3.3	Engine/pump position	9	7.5	Troubleshooting	24
3.4	Hand brake	9	8	REPAIRS	25
3.5	System diagram	10	8.1	Inlet valve pusher	25
3.6	Technical data	11	8.2	Inlet valve	25
4	SPRAY GUN SETUP	12	8.3	Outlet valve	26
4.1	Positioning the SmartArm	12	WARRANTY	27	
4.2	Installing the second gun kit (optional)	12	SPRAY GUN POSITIONS	106	
4.3	Adjusting the trigger tension	13	STRIPING TIPS	107	
4.4	Attach spray hose(s)	14	STRIPING TIP CHART	108	
4.5	Position spray gun(s)	14	ACCESSORIES	110	
4.6	Setting the trigger selector (if applicable)	15			
5	OPERATION	16			
5.1	Setup	16			
5.2	Starting the engine	16			
5.3	Preparing a new sprayer	17			
5.4	Preparing to paint	17			
5.5	Pressure relief procedure	18			
5.6	Operating the front caster	18			
5.7	Cleaning a clogged tip	18			
5.8	Short term storage	19			
5.9	Handling the high pressure hose	19			

1 SAFETY REGULATIONS FOR AIRLESS SPRAYING

1.1 EXPLANATION OF SYMBOLS USED

This manual contains information that must be read and understood before using the equipment. When you come to an area that has one of the following symbols, pay particular attention and make certain to heed the safeguard.



→ This symbol indicates a potential hazard that may cause serious injury or loss of life. Important safety information will follow.



Attention

→ This symbol indicates a potential hazard to you or to the equipment. Important information that tells how to prevent damage to the equipment or how to avoid causes of minor injuries will follow.



→ Danger of skin injection



→ Danger of fire from solvent and paint fumes



→ Danger of explosion from solvent, paint fumes and incompatible materials



→ Danger of injury from inhalation of harmful vapors



→ Notes give important information which should be given special attention.



→ **WARNING! CALIFORNIA PROPOSITION 65 WARNING**

This product can expose you to chemicals including lead, which are known to the State of California to cause cancer, birth defects, or other reproductive harm.

The engine exhaust from models with gas-powered engines can expose you to carbon monoxide which is known to the State of California to cause cancer, birth defects, and other reproductive harm.

For more information go to www.P65warnings.ca.gov.

1.2 SAFETY HAZARDS



HAZARD: INJECTION INJURY

A high pressure stream produced by this equipment can pierce the skin and underlying tissues, leading to serious injury and possible amputation.

Do not treat a spraying injury as a harmless cut. In case of injury to the skin through coating materials or solvents, consult a doctor immediately for quick and expert treatment. Inform the doctor about the coating material or solvent used.

PREVENTION:

- NEVER aim the gun at any part of the body.
- NEVER allow any part of the body to touch the fluid stream. DO NOT allow body to touch a leak in the fluid hose.
- NEVER put your hand in front of the gun. Gloves will not provide protection against an injection injury.
- ALWAYS lock the gun trigger, shut the fluid pump off and release all pressure before servicing, cleaning the tip guard, changing tips, or leaving unattended. Pressure will not be released by turning off the engine. The PRIME/SPRAY valve or pressure bleed valve must be turned to their appropriate positions to relieve system pressure.
- ALWAYS keep tip guard in place while spraying. The tip guard provides some protection but is mainly a warning device.
- ALWAYS remove the spray tip before flushing or cleaning the system.
- NEVER use a spray gun without a working trigger lock and trigger guard in place.
- All accessories must be rated at or above the maximum operating pressure range of the sprayer. This includes spray tips, guns, extensions, and hose.



HAZARD: HIGH PRESSURE HOSE

The paint hose can develop leaks from wear, kinking and abuse. A leak can inject material into the skin. Inspect the hose before each use.

PREVENTION:

- Avoid sharp bending or kinking of the high-pressure hose. The smallest bending radius amounts to about 8" (20 cm).
- Do not drive over the high-pressure hose. Protect against sharp objects and edges.
- Replace any damaged high-pressure hose immediately.
- Never repair damaged high-pressure hoses yourself!
- Electrostatic charging of spray guns and the high-pressure hose is discharged through the high-pressure hose. For this reason the electric resistance between the connections of the high-pressure hose must be equal to or lower than 1MΩ.
- For reasons of function, safety and durability use only original Titan high-pressure hoses.
- Before each use, check all hoses for cuts, leaks, abrasion or bulging of cover. Check for damage or movement of couplings. Immediately replace the hose if any of these conditions exist. Never repair a paint hose. Replace it with another earthed high-pressure hose.
- Make sure power cord, air hose and spray hoses are routed in such a manner to minimize slip, trip and fall hazard.
- Do not put the high-pressure hose into solvents. Use only a wet cloth to wipe down the outside of the hose.



HAZARD: EXPLOSION OR FIRE

Flammable vapors, such as solvent and paint vapors, in work area can ignite or explode.



PREVENTION:

- Use equipment only in well ventilated area. Keep a good supply of fresh air moving through the area to keep the air within the spray area free from accumulation of flammable vapors. Keep pump assembly in well ventilated area. Do not spray pump assembly.
- Do not use the unit in work places which are covered by the explosion protection regulations. The unit is not designed to be explosion protected. Do not operate the device in explosive areas (zone 0, 1 and 2).
- Do not fill fuel tank while engine is running or hot; shut off engine and allow to cool. Fuel is flammable and can ignite or explode if spilled on a hot surface.
- Eliminate all ignition sources, such as pilot lights, cigarettes, portable electric lamps and plastic drop cloths (potential static arc).
- Keep work area free of debris, including solvent, rags and gasoline.
- Do not plug or unplug power cords, or turn power or light switches on or off when flammable vapors are present.
- Ground equipment and conductive objects in work area. Make sure grounding chain is in place and reaches the ground.
- Use only grounded hoses.
- Hold spray gun firmly to the side of a grounded pail when triggering into pail.
- If there is static sparking or if you feel a shock, stop operation immediately.
- Know the contents of the paint and solvents being sprayed. Read all material Safety Data Sheets (SDS) and container labels provided with the paints and solvents. Follow the paint and solvent manufacturer's safety instructions.
- Do not use a paint or solvent containing halogenated hydrocarbons. Such as chlorine, bleach, mildewcide, methylene chloride and trichloroethane. They are not compatible with aluminum. Contact the coating supplier about compatibility of material with aluminum.
- Keep a fire extinguisher in work area.



HAZARD: HAZARDOUS VAPORS

Paints, solvents, and other materials can be harmful if inhaled or come in contact with body. Vapors can cause severe nausea, fainting, or poisoning.

PREVENTION:

- Wear respiratory protection when spraying. Read all instructions supplied with the mask to be sure it will provide the necessary protection.
- All local regulations regarding protection against hazardous vapors must be observed.
- Wear protective eyewear.
- Protective clothing, gloves and possibly skin protection cream are necessary for the protection of the skin. Observe the regulations of the manufacturer concerning coating materials, solvents and cleaning agents in preparation, processing and cleaning units.



HAZARD: GENERAL

This product can cause severe injury or property damage.

PREVENTION:

- Follow all appropriate local, state, and national codes governing ventilation, fire prevention, and operation.
- Pulling the trigger causes a recoil force to the hand that is holding the spray gun. The recoil force of the spray gun is particularly powerful when the tip has been removed and high pressure has been set on the airless pump. When cleaning without a spray tip, set the pressure control knob to the lowest pressure.
- Use only manufacturer authorized parts. User assumes all risks and liabilities when using parts that do not meet the minimum specifications and safety devices of the pump manufacturer.
- ALWAYS follow the material manufacturer's instructions for safe handling of paint and solvents.
- Clean up all material and solvent spills immediately to prevent slip hazard.
- Wear ear protection. This unit can produce noise levels above 85 dB(A).
- Device is very heavy. Three-person lift is required.
- Never leave this equipment unattended. Keep away from children or anyone not familiar with the operation of airless equipment.
- Do not spray on windy days.
- The device and all related liquids (i.e. hydraulic oil) must be disposed of in an environmentally friendly way.

1.4 GASOLINE ENGINE SAFETY

1. Gas engines are designed to give safe and dependable service if operated according to instructions. Read and understand the engine manufacturer's Owner's Manual before operating the engine. Failure to do so could result in personal injury or equipment damage.
2. To prevent fire hazards and to provide adequate ventilation, keep the engine at least 1 meter (3 feet) away from buildings and other equipment during operation. Do not place flammable objects close to the engine.
3. People who are not operating the device must stay away from the area of operation due to a possibility of burns from hot engine components or injury from any equipment the engine may be used to operate.
4. Know how to stop the engine quickly, and understand the operation of all controls. Never permit anyone to operate the engine without proper instructions.
5. Gasoline is extremely flammable and is explosive.
6. Refuel in a well-ventilated area with the engine stopped. Do not smoke or allow flames or sparks in the refueling area or where gasoline is stored.
7. Do not overfill the fuel tank. After refueling, make sure the tank cap is closed properly and securely.
8. Be careful not to spill fuel when refueling. Fuel vapor or spilled fuel may ignite. If any fuel is spilled, make sure the area is dry before starting the engine.
9. Never run the engine in an enclosed or confined area. Exhaust contains poisonous carbon monoxide gas; exposure may cause loss of consciousness and may lead to death.
10. The muffler becomes very hot during operation and remains hot for a while after stopping the engine. Be careful not to touch the muffler while it is hot. To avoid severe burns or fire hazards, let the engine cool before transporting it or storing it indoors.
11. Never ship/transport sprayer with gasoline in the tank.



DO NOT use this equipment to spray water or acid.



Attention

Do not lift by cart handle when loading or unloading.

1.5 FUELING



Gasoline is extremely flammable and is explosive under certain conditions.

FUEL SPECIFICATIONS

Use automotive gasoline that has a pump octane number of 86 or higher, or that has a research octane number of 91 or higher.



If “spark knock” or “pinging” occurs at a steady engine speed under normal load, change brands of gasoline. If spark knock or pinging persists, consult an authorized dealer of the engine manufacturer. Failure to do so is considered misuse, and damage caused by misuse is not covered by the engine manufacturer’s limited warranty.

Occasionally you may experience light spark knock while operating under heavy loads. This is no cause for concern, it simply means your engine is operating efficiently.

- Unleaded fuel produces fewer engine and spark plug deposits and extends the life of the exhaust system components.
- Never use stale or contaminated gasoline or an oil/gasoline mixture. Avoid getting dirt, dust, or water in the fuel tank.

GASOLINES CONTAINING ALCOHOL

Be sure the octane rating is at least as high as that recommended by the engine manufacturer. Do not use gasohol that contains more than 10% ethanol. Do not use gasoline containing methanol.



Fuel system damage or engine performance problems resulting from the use of fuels that contain alcohol is not covered under the warranty.

2 MAIN AREAS OF APPLICATION

2.1 APPLICATION

This airless line striper is a precision power tool used to spray many types of material for many types of applications including parking lots, curbs, and athletic fields.

Read and follow this instruction manual carefully for proper operating instructions, maintenance, and safety information.

2.2 COATING MATERIALS

PROCESSIBLE COATING MATERIALS

Paints containing solvents, two-component coating materials, dispersion and latex paints.

No other materials should be used for spraying without Titan's approval.

i	Pay attention to the Airless quality of the coating materials to be processed.
----------	--

VISCOSITY

The unit is able to process coating materials with up to 20,000 mPas. If highly viscous coating materials cannot be taken in or the performance of the unit is too low, the paint must be diluted in accordance with the manufacturer's instructions.

i	Attention: Make sure, when stirring up with motor-driven agitators that no air bubbles are stirred in. Air bubbles disturb when spraying and can, in fact, lead to interruption of operation.
----------	---

COATING MATERIALS WITH ABRASIVE MATERIALS

These particles have a strong wear and tear effect on valves and tips, but also on the spray gun. This impairs the durability of these wearing parts considerably.

FILTERING

Sufficient filtering is required for fault-free operation. The unit is equipped with a suction filter, an insertion filter in the spray gun and a high pressure filter on the unit. Regular inspection of these filters for damage or soiling is highly recommended.

2.3 GLASS BEAD DISPENSER KITS (SOLD SEPARATELY)

i	Add an optional glass bead dispensing system to deposit retro-reflective glass beads on traffic/airport paint lines. The dispenser is mounted directly behind the spray gun.
----------	--

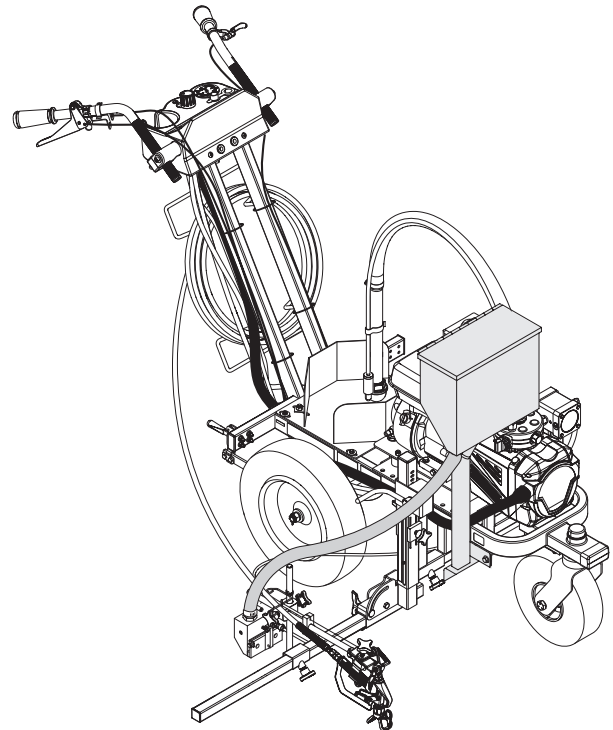

DESCRIPTION	ORDER #
1-Gun Kit w/Hopper, 4-6" line width	424-826
2-Gun Kit w/Hopper, 4-6" line width	424-836
1-Gun Kit w/Hopper, 12" line width	424-840
2nd-Gun Kit, 12" line width	424-841
Bead Dispenser bracket kit (required for Bead Dispenser)	290181
2nd-Gun Kit, 4-6" line width	424-816

3 DESCRIPTION OF UNIT

3.1 AIRLESS PROCESS

A diaphragm pump takes in the coating material by suction and conveys it to the tip. Pressed through the tip at a pressure of up to a maximum of 3300 psi (228 bar, 22.8 MPa), the coating material is atomized. This high pressure has the effect of micro fine atomization of the coating material.

As no air is used in this process, it is described as an AIRLESS process.

This method of spraying has the advantages of finest atomization, cloudless operation and a smooth, bubble-free surface. As well as these, the advantages of high production speed and convenience must be mentioned.

3.2 INSTRUCTION MANUALS LIST

The following is a list of the available instruction manuals for this unit.

Online items can be downloaded at www.titantool.com

DESCRIPTION	HOW TO FIND
Operation Manual	<ul style="list-style-type: none"> included with unit online
Service manual, spare parts, accessories	<ul style="list-style-type: none"> online

3.3 ENGINE / PUMP POSITION



The engine and pump can be positioned in three different places on the cart in order to shift the weight of the unit based on personal preference.

1. If the unit has been used already, make sure the unit is not running and has been depressurized (see section 5.5 for pressure relief procedure).
2. Loosen and remove the four wing nuts and bolts (fig. 1, item 1) underneath the cart that secure the engine and pump assembly to the cart.

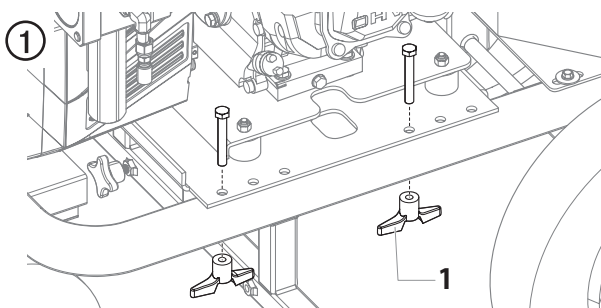

3. Carefully slide the the engine / pump assembly to the desired position, lining up the holes in the engine place with the corresponding holes in the cart.
4. Replace the bolts and secure with the wing nuts. Tigthen the wing nuts by hand.

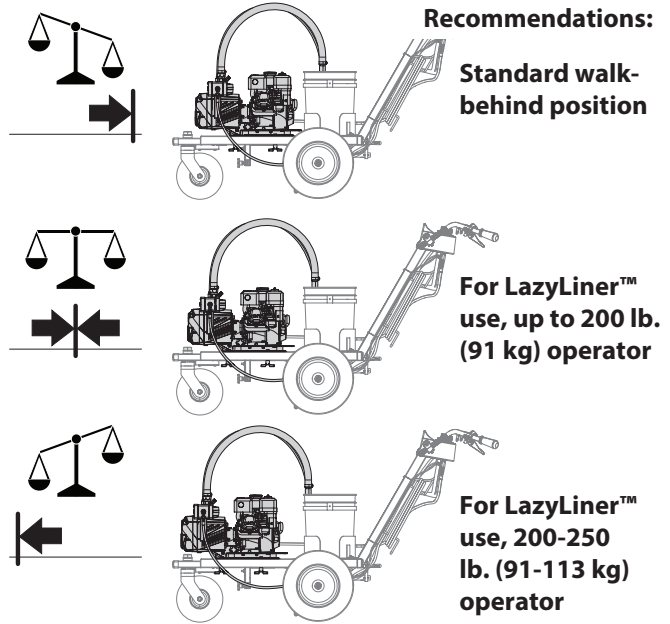



3.4 HAND BRAKE

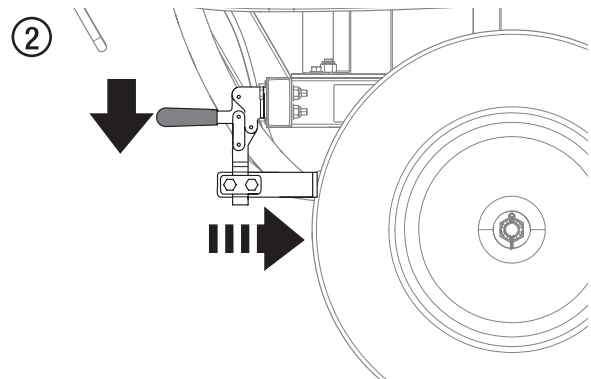

Be sure to engage the hand brake located behind the right rear wheel whenever using the stencil gun or whenever the sprayer is not in use in order to keep it from inadvertently rolling down an incline.



3.5 SYSTEM DIAGRAM (2407312 SHOWN)

- | | | |
|---|-------------------------------|---|
| 1. Gun trigger | 8. Spray gun | 16. High-pressure hose connection |
| 2. Caster trigger | 9. Tip guard with airless tip | a) Pump outlet |
| 3. Pump hose (50', connects 16a/16b) | 10. Pressure gauge | b) Manifold inlet |
| 4. 1-gun hose (6', connects to 8) | 11. Pressure control knob | 17. High pressure filter |
| 5. 2-gun hose connection/shutoff valve | 12. Suction tube | 18. Hydraulic pump assembly |
| 6. Suction filter | 13. Bleed hose | 19. SmartArm™ assembly (model 2407312 only) |
| 7. Relief valve | 14. Gasoline engine | 20. Second gun kit (optional) |
| PRIME =  | 15. Pusher stem | 21. 2-gun hose (12', connects to 5) |
| SPRAY =  | | |

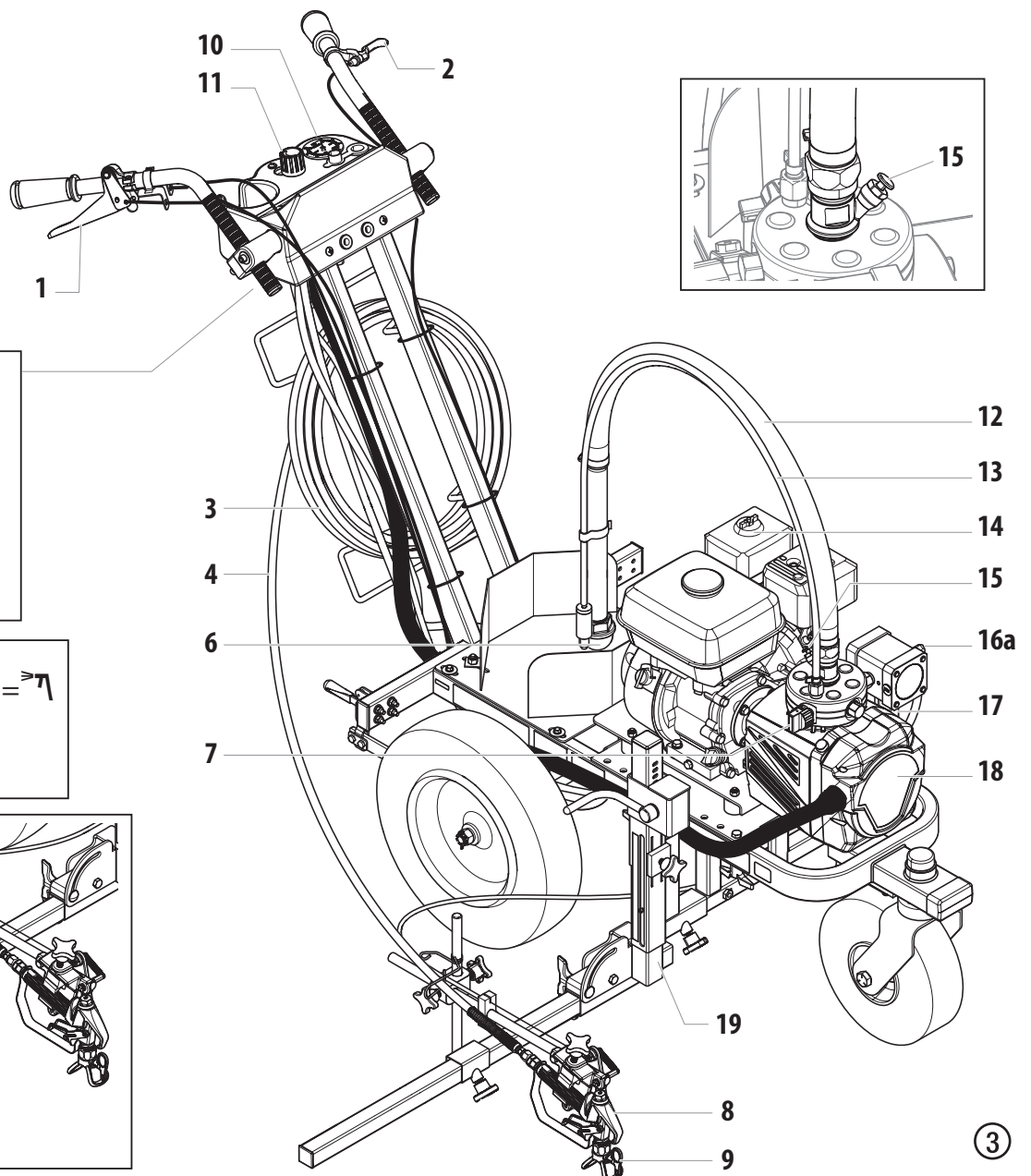
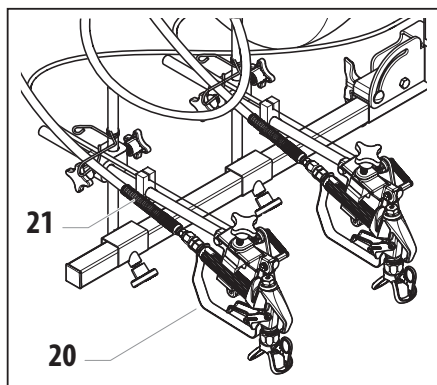
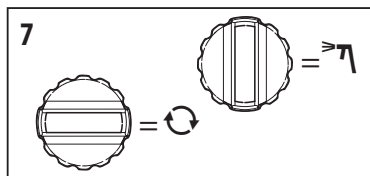
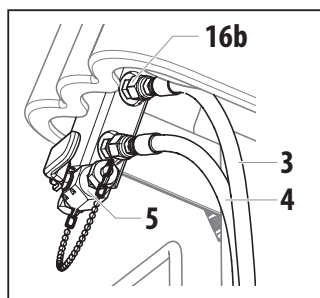
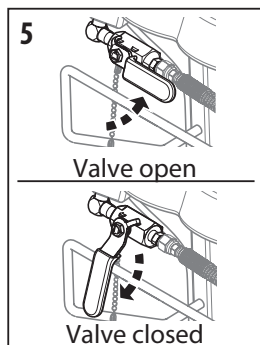

3.6 TECHNICAL DATA

Gasoline engine, power	
	160cc (Honda)
Fuel capacity	
	0.66 US gal (2.5 l)
Max. operating pressure	
	3300 psi (22,8 MPa, 228 bar)
Max. volume flow	
	1.25 gal/min (4.7 l/min)
Volume flow at 0.6 MPa (6 bar) with water	
	1.59 gal/min (6.01 l/min)
Material hose connection	
	1/4"-18 NPSM
Hose lengths	
1-gun (primary striping)	6' (P/N 316-533)
2-gun (secondary striping, stenciling)	12' (P/N 2408659)
Pump hose	50' (P/N 316-505)
Spray tips included	
Striping	419 (P/N 697-419) x 2
Stenciling	SC-6, 517 (P/N 662-517A) x 1
Max. size of tip with a spray gun	
	0.035" – 0.89 mm
Max. viscosity	
	20,000 mPas
Max. temperature of the coating material	
	109° F (43 °C)
Empty weight	
Model 2407312	227 lbs (103 kg)
Model 2407313	222 lbs (100.7 kg)
Dimensions (L x W x H)	
Model 2407312	73" x 32" x 43.4"
Model 2407313	73" x 32" x 43.4"
Hydraulic oil filling quantity	
Hydraulics housing	1.10 liter
Max. vibration at the spray gun	
	lower than 2.5 m/s ²
Max. sound pressure level	
	85 dB (A)*

* Place of measurement: 1 m distance from unit and 1.60m above floor, 12 MPa (120 bar) operating pressure, reverberant floor

OPERATING TEMPERATURE

This equipment will operate correctly in its intended ambient, at a minimum between +50°F (10°C) and 104°F (+40°C).

RELATIVE HUMIDITY

The equipment will operate correctly within an environment at 50% RH, 104°F (+40°C). Higher RH may be allowed at lower temperatures.

Measures shall be taken by the Purchaser to avoid the harmful effects of occasional condensation.

ALTITUDE

This equipment will operate correctly up to 2100 m (6890 ft) above mean sea level.



Honda service center can add a high-altitude kit if operation at higher elevation is required.

TRANSPORTATION AND STORAGE

This equipment will withstand, or has been protected against, transportation and storage temperatures of -13°F (-25°C) to 131°F (55°C) and for short periods up to 150°F (70°C).

It has been packaged to prevent damage from the effects of normal humidity, vibration and shock.

4 SPRAY GUN SETUP



Follow the steps in this section in order to properly install and/or position the spray gun(s).

4.1 POSITIONING THE SMARTARM (MODEL 2407312)



The SmartArm comes pre-assembled to the right side of the frame (as looking from the rear of the unit). If it needs to be moved to the other side, follow these steps.

1. Loosen the gun riser clamp(s) (Fig. 4, item 1) and slide the gun riser(s) off the gun support bar (2).



The cable ties that secure the gun trigger cables to the bottom of the frame will need to be cut in order to allow enough slack for the gun support bar and gun(s) to be removed.

④

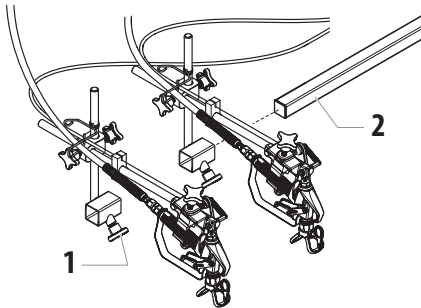

2. Loosen the main SmartArm knob (Fig. 5, item 1) and pull the entire SmartArm assembly (2) from the cart frame.

⑤

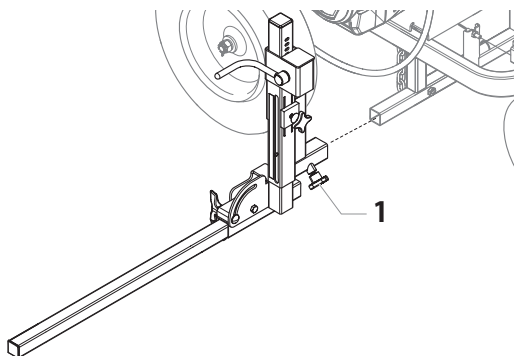

3. Flip the SmartArm assembly (Fig. 6, item 1) around and install on the other side of the frame. Tighten the SmartArm knob (2) which is now facing the rear of the unit.
4. Reinstall the gun riser(s) onto the gun support bar.

⑥

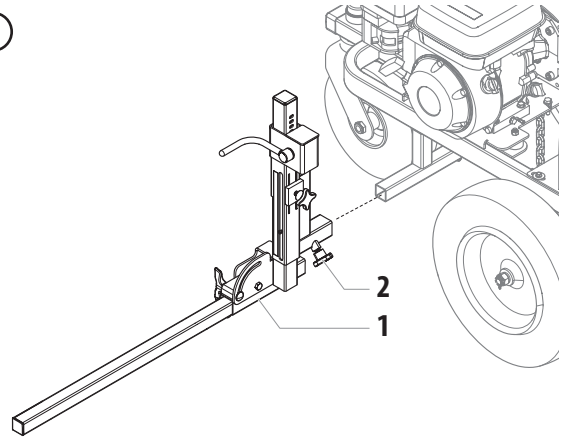

5. Resecure the gun trigger cables to the bottom of the cart using new cable ties.



Make sure the gun trigger cables and spray hoses are positioned/routed in such a way as to not be obstructing the wheels or interfering in any way with the other components of the sprayer.

4.2 INSTALLING THE SECOND GUN KIT (OPTIONAL)



Both models have an optional second spray gun kit included. Follow these instructions to install the second spray gun.

1. Assemble the second gun kit as shown. Tighten the knobs on the clamp to secure the components.

⑦

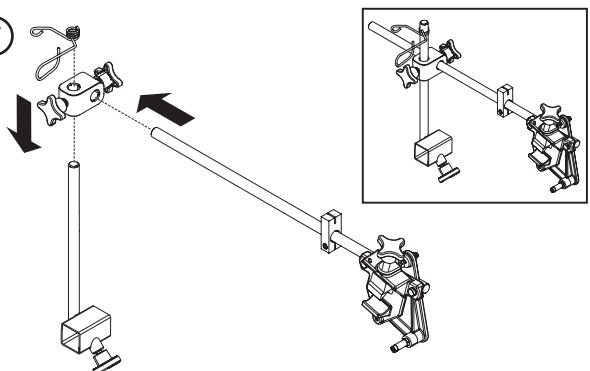

2. Slide the second gun riser (Fig. 8, item 1) over the end of the gun support bar (2) to the desired horizontal position. Tighten the gun riser clamp (3) to secure into place.
3. Run the second gun cable through the block (4) and cable guides, underneath the frame and back towards the cart handle. Use the tie wraps to secure the cable to the frame.

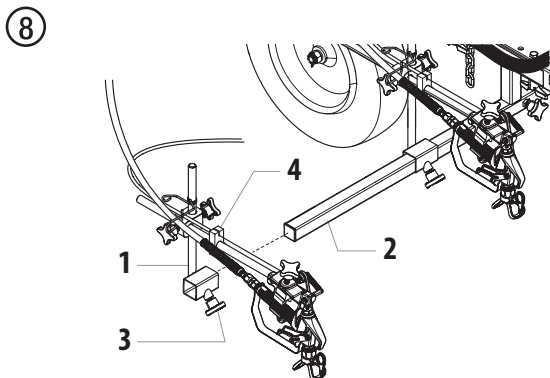

Make sure the cable is not touching the tires or interfering with the mobility of the cart in any way.

4. Insert the gun cable assembly (Fig. 9, item 5) into the hole of the control guide (6) until it snaps into place.
5. Attach the hooked end of the cable into the hole of the lever plate (7).

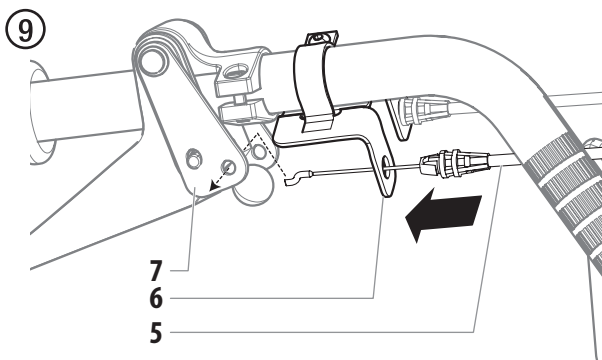

4.3 ADJUSTING THE TRIGGER TENSION

i	Use the following procedure to adjust the spring tension of the trigger lever on the gun holder assembly. The proper tension ensures that the gun will shut off when the gun trigger is released.
i	Always keep the trigger lock on the spray gun in the locked position while making adjustments to the system.

1. Using a wrench, loosen the bolt on the cable block (1).
2. Move the cable block in the appropriate direction to create a gap of 1/32" to 1/16" (0.8-1.6 mm) between the trigger lever (2) and spray gun trigger (3).
 - a. Slide the cable block toward the gun to increase the gap between the trigger lever and spray gun trigger.
 - b. Slide the cable block away from the gun to decrease the gap between the trigger lever and spray gun trigger.

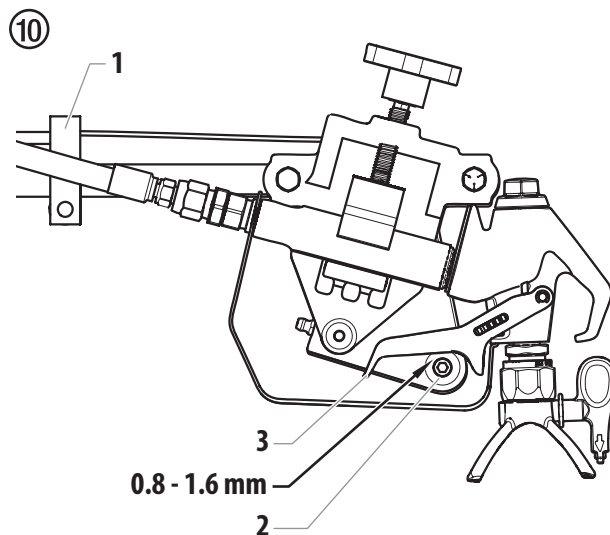

3. Tighten the set screw securely.

4.4 ATTACH SPRAY HOSE(S)



If you plan on using both guns, make sure the shutoff valve handle for the second gun connection (located under the dashboard) is in the open position (handle is in line with the valve).

If you plan on using one gun, make sure the valve handle is in the closed position (handle is perpendicular to the valve) and that the plug is threaded onto the end of the valve.

ONE GUN SETUP

1. Using a wrench, thread the 50' (15m) pump hose to the pump outlet fitting on the sprayer. Tighten securely.
2. Using a wrench, thread the other end of the 50' (15m) airless hose to the **top** fitting (fig. 12, item 1) of the manifold located underneath the dashboard.
3. Attach the 6' (2m) airless hose to the spray gun. Using two wrenches (one on the gun and one on the hose), tighten securely.
4. Using a wrench, thread the other end of the 6' airless hose to the **bottom** fitting (2) of the manifold located underneath the dashboard.

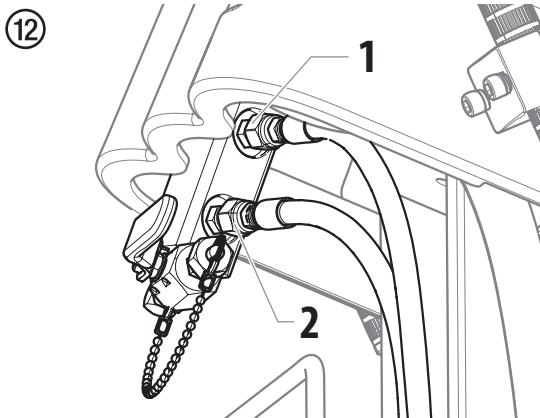

TWO-GUN SETUP (OPTIONAL)

1. Perform the 'One Gun Setup' steps, above for the first spray gun.
2. Loosen and remove the cap that is attached to the second gun connection ball valve underneath the dashboard.
3. Using a wrench, thread the 12' (4m) airless spray hose to the second gun connection. Tighten securely.
4. Attach the 12' (3m) airless hose to the second spray gun. Using two wrenches (one on the gun and one on the hose), tighten securely.

4.5 POSITION SPRAY GUN(S)

1. Disengage the trigger cable from the tensioning clamp (1).

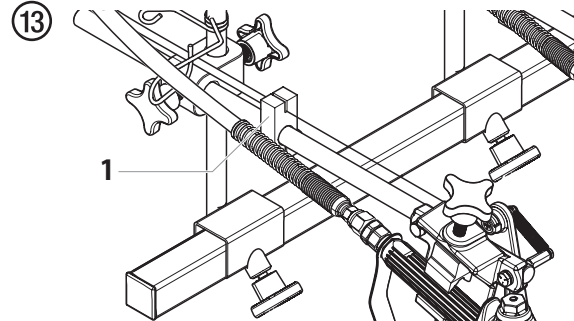

Always disengage the trigger cable from the tensioning clamp before making any adjustments to the spray gun position.

MODEL 2407313 (NO SMARTARM)

1. Loosen the support bar clamp (Fig. 14, item 2) and slide the gun support bar to the desired horizontal position. The gun should be positioned wide enough so that the wheel will not roll through the spray pattern.
2. Loosen the gun riser clamp (3) and slide the spray gun to the desired vertical position.
3. Reinstall the trigger cable to the tensioning clamp (1).
4. Repeat steps 1 through 3 for the second spray gun (if applicable).

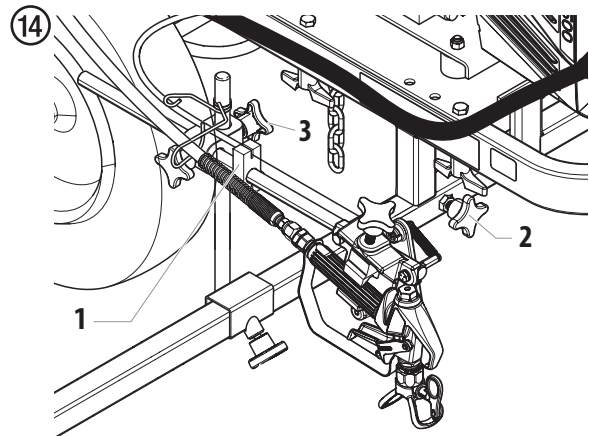

MODEL 2407312 (SMARTARM)

1. Loosen the gun holder clamps (Fig. 15, item 2) and slide the risers to the desired horizontal position.
2. Loosen the gun riser clamp (3) and slide the spray gun to the desired vertical position.
3. Reinstall the trigger cable to the tensioning clamp (1).
4. Repeat steps 1 through 3 for the second spray gun (if applicable).

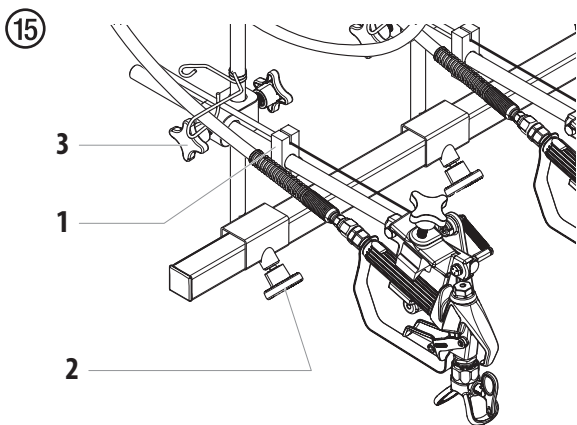

5. Once both guns are installed, their vertical position can be adjusted simultaneously.
 - a. Loosen the vertical support clamp knob (Fig. 16, item 1) on the riser.
 - b. Turn the crank (2) to adjust the overall height of the spray guns.
 - c. Once at desired height, re-tighten the vertical support clamp knob (1).

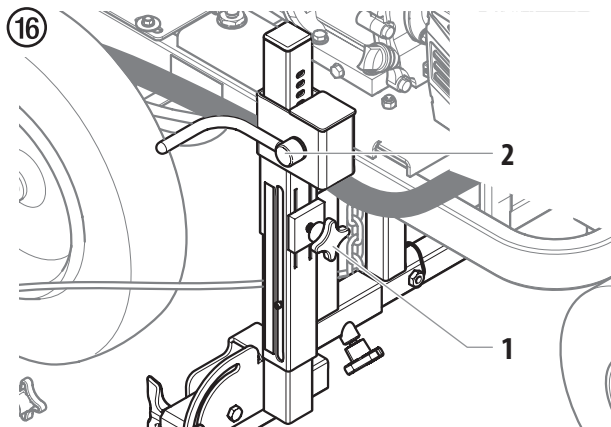

i If lift/tilt assembly has excessive friction during operation, spray the tubes with dry graphite lubricant.

ALL MODELS

i	The height of the spray gun affects the width of the spray pattern (i.e., the lower the gun, the smaller the line width). Tip size also affects line width.
i	It is recommended that both spray guns be installed at the same height as a starting point. The gun heights can be adjusted individually based on spraying needs (i.e. spraying a curb or spraying two lines of different widths).

4.6 SETTING THE TRIGGER SELECTOR (IF APPLICABLE)

1. Set the trigger selector for proper spray gun operation (Fig. 17). The right handlebar triggers the gun or guns. The selector on the trigger must be set for the first gun, both guns, or the second gun.

Attention Always turn the trigger lock on the spray gun to the locked position before making any adjustments to the trigger selector. Also, release the trigger cable from its block by lifting the cable up and out of the block. There will be a brief triggering of the gun while releasing the trigger cable.

- a. **First Gun** — The first gun position is with the selector in the left position. Push the lever toward the inside of the frame until the pin engages the left plate.
- b. **Both Guns** — The dual gun position is with the selector in the center position. Push the lever toward the center position until the pin engages both plates. The pin must engage both plates.
- c. **Second Gun** — The second gun position is with the selector in the right position. Push the lever away from the inside of the frame until the pin engages the right plate.

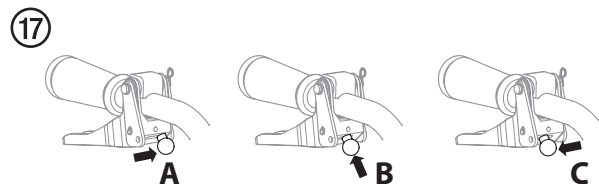

5 OPERATION



This equipment produces a fluid stream at extremely high pressure. Read and understand the warnings in the Safety Precautions section at the front of this manual before operating this equipment.

5.1 SETUP

1. Ensure that the siphon hose and the return hose are attached and secure.



If using the 2nd gun, make sure the valve is open. (handle in line with the valve).
If not using the 2nd gun, make sure the valve is closed (handle perpendicular to the valve).
Refer to section 4.4.

2. Fully depress the pusher stem (Fig. 18, item 4) to make sure the inlet valve is free.

18

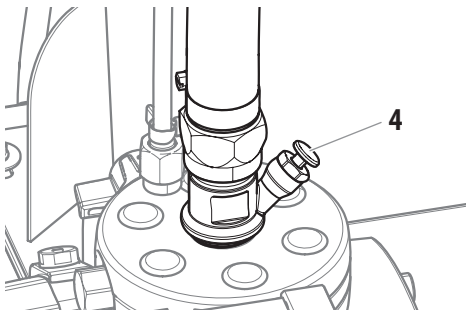

3. Check the engine oil level daily before starting the sprayer. The gasoline engine oil level is determined by the engine manufacturer. Refer to the engine manufacturer's service manual supplied with this sprayer.
4. Make sure the sprayer is grounded/earthed. All sprayers are equipped with an grounding/earthing chain. Make sure the chain reaches all the way to the ground. Check your local electrical regulations for detailed grounding/earthing instructions.



Proper grounding/earthing is important. The passage of some materials through the nylon fluid hose will build up a static electric charge, which if discharged, could ignite solvent vapors present and create an explosion.

5. Strain all paints with a nylon strainer to ensure trouble free operation and freedom from frequent cleaning of the suction filter and gun filter.
6. Make sure the spray area is well ventilated to prevent hazardous operation with volatile solvents or exhaust fumes.

5.2 STARTING THE ENGINE



Follow these instructions whenever prompted in this manual to start the engine.

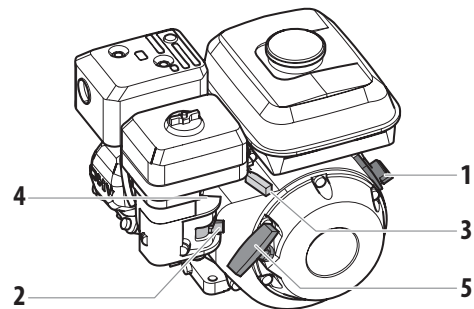

1. Move the fuel valve lever (Fig. 19, item 2) to the open position.
2. Move the throttle lever (3) to its middle point.
3. Move the choke lever (4) to the closed position for a cold engine or to the open position for a warm engine,
4. Turn the engine switch (1) to the ON position, and
5. Pull the starter rope (5) briskly until the engine starts.

19



If choke lever (4) was moved to closed position to start the engine, it must be opened again once the engine is running.

5.3 PREPARING A NEW SPRAYER

	If this unit is new, it is shipped with test fluid in the fluid section to prevent corrosion during shipment and storage. This fluid must be thoroughly cleaned out of the system with mineral spirits before you begin spraying.
 Attention	Always keep the trigger lock on the spray gun in the locked position while preparing the system. Refer to the spray gun instruction manual for trigger lock instructions.
	Make sure that the spray gun does not have a tip or tip guard installed.

1. Immerse the suction tube (Fig. 20, Item 1) and return hose (2) into a container with mineral spirits.
2. Turn the pressure control knob counterclockwise (3) to minimum pressure.
3. Turn the relief valve (4) to PRIME (↻ circulation).

②0

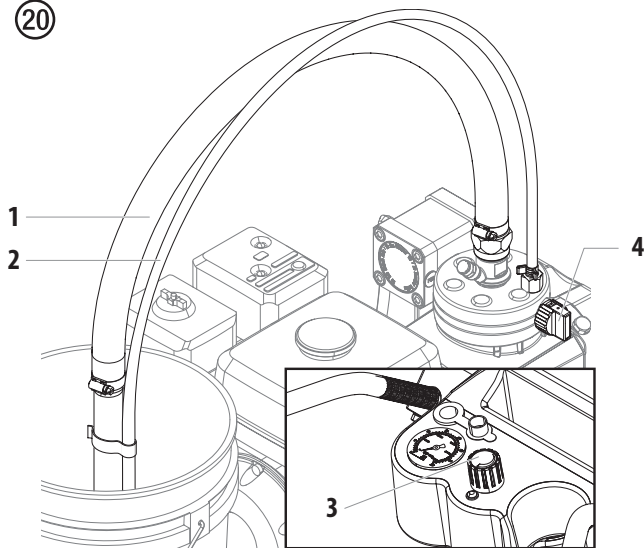

4. Start the engine (refer to section 5.2).
5. Wait until the cleaning agent exudes from the return hose.
6. Turn the relief valve (4) to SPRAY (↗ spray).
7. Unlock the spray gun (refer to spray gun manual).
8. Aim the spray gun into an open waste container. Pull the gun trigger on the right handlebar.
9. Spray the cleaning agent from the unit into an open, grounded (earthed) collecting container.

5.4 PREPARING TO PAINT

	Make sure that the spray gun does not have a tip or tip guard installed.
---	--

1. Immerse the suction tube (Fig. 20, Item 1) and return hose (2) into the coating material container.
2. Turn the pressure control knob counterclockwise (3) to minimum pressure.
3. Turn the relief valve (4) to PRIME (↻ circulation).
4. Start the engine (refer to section 5.2).
5. Turn the relief valve (4) to SPRAY (↗ spray).
6. Aim the spray gun into an open waste container. Pull the gun trigger on the right handlebar.
7. Trigger the spray gun several times and spray into a collecting container until the coating material exits the spray gun without interruption.

	Ground/Earth the gun by holding it against the edge of the metal container while flushing. Failure to do so may lead to a static electric discharge, which may cause a fire.
--	--

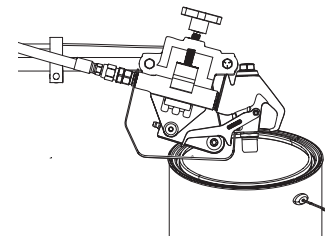

8. Lock the gun by pushing the gun trigger lock to the locked position (refer to spray gun manual).
9. Attach tip guard and tip to the gun as instructed by the tip guard or tip manuals.

	POSSIBLE INJECTION HAZARD. Do not spray without the tip guard in place. Never trigger the gun unless the tip is in either the spray or the unclog position. Always engage the gun trigger lock before removing, replacing or cleaning tip.
---	---

10. Increase the pressure by slowly turning up the pressure control knob.

Check the spray pattern and increase the pressure until the atomization is correct.

Always turn the pressure control knob to the lowest setting with good atomization.

11. The unit is ready to spray.



Turning the pressure up higher than needed to atomize the paint will cause premature tip wear and additional overspray.

5.5 PRESSURE RELIEF PROCEDURE



Be sure to follow the Pressure Relief Procedure when shutting the unit down for any purpose, including servicing or adjusting any part of the spray system, changing or cleaning spray nozzles, or preparing for cleanup.

1. Lock the spray gun by pushing the gun trigger lock to the locked position.
2. Set the pressure to minimum by turning the pressure control knob fully counterclockwise.
3. Trigger the gun to remove any pressure that may still be in the hose.
4. Move the throttle lever to the slow position.
5. Turn the engine switch to the OFF position.
6. Unlock the gun by pushing the gun trigger lock to the unlocked position (refer to spray gun manual).
7. Hold the metal part of the gun firmly to the side of a metal waste container to ground/earth the gun and avoid a build up of static electricity.
8. Turn the relief valve to PRIME (↻ circulation).
9. Lock the gun by pushing the gun trigger lock to the locked position (refer to spray gun manual).

5.6 OPERATING THE FRONT CASTER



The front caster on the cart is designed to track the sprayer in either a straight line or allow free motion.

Standing behind the sprayer, the trigger on the left handle of the cart controls the operation of the front caster.

1. To lock the front caster in the straight line position, squeeze then release the caster trigger and move the sprayer forward.
2. To allow free motion of the front caster, squeeze and hold the caster trigger.

5.7 CLEANING A CLOGGED TIP



If the spray pattern becomes distorted or stops completely while pulling the trigger, perform the steps below.

1. Turn the relief valve to PRIME (↻ circulation).
2. If the tip clogs, rotate the tip handle 180° until the arrow on the handle is facing the opposite of the spray direction and the handle clicks in the reverse position (Fig. 21).
3. Turn the relief valve to SPRAY (↗ spray).

21

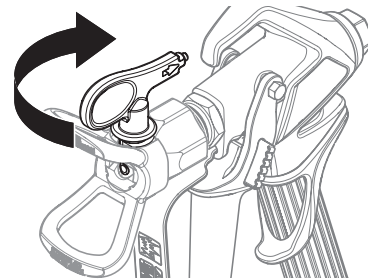

4. Trigger the gun once so that the pressure can blow the clog out. NEVER use the tip in the reverse position for more than ONE trigger pull at a time. This procedure can be repeated until the tip is free of clogging.





The flow from the spray tip is at very high pressure. Contact with any body part may be dangerous. Do not place finger on gun outlet. Do not point the gun at any person. Never operate the spray gun without the proper tip guard.



5.8 SHORT TERM STORAGE

	<p>Follow these steps if stopping work for up to 15 hours. Only follow these steps if you used latex - or water-based spray materials.</p> <p>If using solvent-based spray materials, follow all the steps in section 6, Cleanup</p>
---	--

1. Follow the "Pressure Relief Procedure" found in the Operation section of this manual, section 5.5.
2. Place the spray gun in a plastic bag, or drop it into a bucket of water.
3. Leave the suction tube and return hose immersed in the coating material or immerse it into a corresponding cleaning agent.
4. Cover the coating material with plastic and place unit in a cool, shaded spot to keep material from drying out.

 Attention	<p>If fast-drying or two-component coating material is used, ensure that the unit is rinsed with a suitable cleaning agent within the processing time.</p>
	<p>When ready to being spraying again, remove the plastic from the material container and restart the sprayer by following the steps in section 5.4.</p>

5.9 HANDLING THE HIGH-PRESSURE HOSE



	<p>The unit is equipped with a high-pressure hose specially suited for airless pumps.</p>
	<p>Danger of injury through leaking high-pressure hose. Replace any damaged high-pressure hose immediately.</p> <p>Never repair defective high-pressure hoses yourself!</p>

The high-pressure hose is to be handled with care. Avoid sharp bends and folds: the smallest bending radius is about 8" (20 cm).



Do not drive over the high-pressure hose. Protect against sharp objects and edges.

Never pull on the high-pressure hose to move the device.

Make sure that the high-pressure hose cannot twist. This can be avoided by using a Titan spray gun with a swivel joint and a hose system.

	<p>The risk of damage rises with the age of the high-pressure hose. Titan recommends replacing high-pressure hoses after 6 years.</p>
	<p>Use only Titan original-high-pressure hoses in order to ensure functionality, safety and durability.</p>

6 CLEANUP

 <p>Attention</p>	<p>The sprayer, hose, and gun should be cleaned thoroughly after daily use. Failure to do so permits material to build up, seriously affecting the performance of the unit.</p>
	<p>Always spray at minimum pressure with the gun nozzle tip removed when using mineral spirits or any other solvent to clean the sprayer, hose, or gun. Static electricity buildup may result in a fire or explosion in the presence of flammable vapors.</p>

6.1 SPECIAL CLEANUP INSTRUCTIONS FOR USE WITH FLAMMABLE SOLVENTS

- Always flush spray gun preferably outside and at least one hose length from spray pump.
- If collecting flushed solvents in a one gallon metal container, place it into an empty five gallon container, then flush solvents.
- Area must be free of flammable vapors.
- Follow all cleanup instructions.

6.2 CLEANING THE SPRAYER

1. Follow the "Pressure Relief Procedure" found in the Operation section of this manual, section 5.5.
2. Remove the gun tip and tip guard and clean with a brush using the appropriate solvent.
3. Place the siphon tube into a container of the appropriate solvent.

 <p>Attention</p>	<p>Use only compatible solvents when cleaning out oil based enamels, lacquers, coal tar, and epoxies. Check with the fluid manufacturer for the recommended solvent.</p>
--	--

4. Place the bleed hose into a metal waste container.
5. Set the pressure to minimum by turning the pressure control knob fully counterclockwise.
6. Turn the relief valve to PRIME (🔄 circulation).
7. Start the engine (refer to section 5.2).
8. Allow the solvent to circulate through the sprayer and flush the paint out of the bleed hose into the metal waste container.

9. Turn the relief valve to SPRAY (🔥 spray).

	<p>Earth the gun by holding it against the edge of the metal container while flushing. Failure to do so may lead to a static electric discharge, which may cause a fire.</p>
---	--

10. Trigger the gun into the metal waste container until the paint is flushed out of the hose and solvent is coming out of the gun.
11. Continue to trigger the spray gun into the waste container until the solvent coming out of the gun is clean.

	<p>For long-term, cold weather storage, or any freezing temperature exposure pump mineral spirits through the entire system.</p> <p>For short-term storage not exposed to freezing temperatures when using latex paint, pump water mixed with Titan Liquid Shield through the entire system (see Accessories section of this manual for part number and product label for dilution instructions).</p>
---	---

12. Follow the "Pressure Relief Procedure" found in the Operation section of this manual.
13. Store the sprayer in a clean, dry area.

 <p>Attention</p>	<p>Do not store the sprayer under pressure.</p>
--	---

6.3 CLEANING UNIT FROM OUTSIDE

 <p>Attention</p>	<p>Never spray down the unit with a high-pressure washer or high-pressure steam cleaners.</p> <p>Do not put the high-pressure hose into solvents. Use only a wet cloth to wipe down the outside of the hose.</p>
--	--

Wipe down unit externally with a cloth which has been immersed in a suitable cleaning agent.

6.4 SUCTION FILTER



A clean suction filter always guarantees maximum feed quantity, constant spraying pressure and problem-free functioning of the unit.

1. Screw off the filter (Fig. 22) from suction tube.
2. Clean or replace the filter.

Carry out cleaning with a hard brush and an appropriate cleaning agent.

22

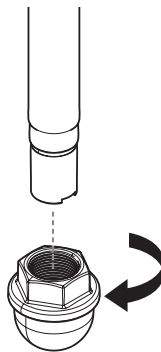

6.5 CLEANING THE HIGH-PRESSURE FILTER



Clean the filter cartridge regularly. A soiled or clogged high-pressure filter can cause a poor spray pattern or a clogged tip.

1. Follow the "Pressure Relief Procedure" found in the Operation section of this manual, section 5.5.
2. Unscrew the filter housing (Fig. 23, Item 1) with a strap wrench.
3. Pull the filter cartridge (2) from the filter support (3).
4. Clean all the parts with the corresponding cleaning agent. If necessary, replace the filter cartridge.
5. Check the O-ring (4), replace it if necessary.
6. Place the filter insert (5) against the filter support (3). Slide the filter cartridge (2) over the bearing spring.
7. Screw in filter housing (1) and tighten it as far as possible with the strap wrench.

23

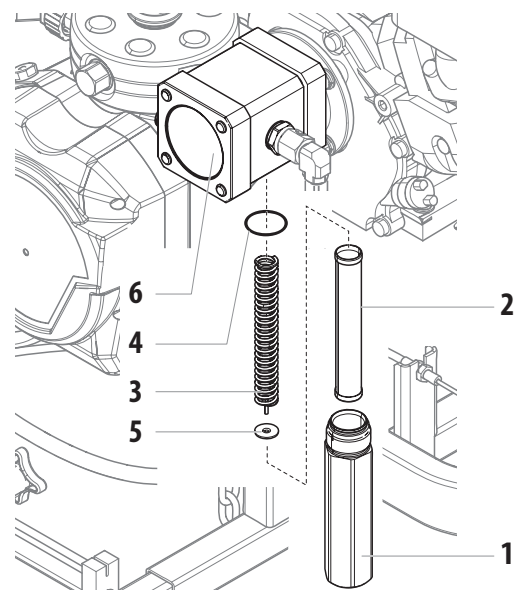

The pulsation dampener contains nitrogen gas and should never be opened. Tampering with the pulsation dampener (i.e. removing the four bolts on the dampener face) will void the warranty.

Contact Titan Technical Service or loc at 1-800-526-5362 or local Titan Authorized Service Center if you believe the pulsation dampener requires service.

6.6 CLEANING AIRLESS SPRAY GUN



Clean the spray gun after each use.

1. Rinse airless spray gun with an appropriate cleaning agent.
2. Clean tip thoroughly with appropriate cleaning agent so that no coating material residue remains.
3. Thoroughly clean the outside of the airless spray gun.

INTAKE FILTER IN AIRLESS SPRAY GUN (FIG. 24)

1. Unclip the top of the trigger guard (1) from the gun head.
2. Using the bottom of the trigger guard as a wrench, loosen and remove the handle assembly (2) from the gun head.
3. Pull the old filter (3) out of the gun head. Clean or replace.
4. Slide the new filter, tapered end first, into the gun head.
5. Thread the handle assembly into the gun head. Tighten with the trigger wrench.
6. Snap the trigger guard back onto the gun head.

24

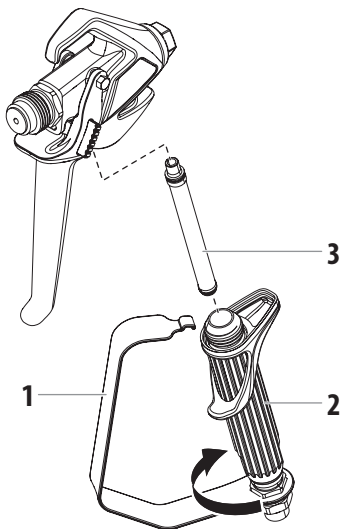

7 SERVICING

7.1 GENERAL SERVICING



We strongly recommend having an annual check carried out by technicians for safety reasons. Please observe all the applicable national regulations.

MINIMUM CHECK BEFORE EVERY STARTUP:

1. Check the high-pressure hose and spray gun connections.

CHECK AT PERIODICAL INTERVALS:

1. Check inlet and outlet valve accordingly for wear. Clean it and replace worn out parts.
2. Check all filter inserts (spray gun, suction system and pump filter), clean and replace if necessary.

7.2 HIGH-PRESSURE HOSE

Inspect the high-pressure hose visually for any notches or bulges, in particular at the transition in the fittings. It must be possible to turn the union nuts freely. A conductivity of less than 1 MΩ must exist across the entire length.



Attention

Have all the electric tests performed by an Authorized Titan Service Center.



The risk of damage rises with the age of the high-pressure hose. Titan recommends replacing high-pressure hoses after 6 years.

7.3 BASIC ENGINE MAINTENANCE (GAS ENGINE)

- For detailed engine maintenance and technical specifications refer to the separate gasoline engine manual.
- All service to the engine should be performed by a dealer authorized by the engine manufacturer.
- Use a premium quality motor oil. 10W30 is recommended for general all temperature use. Other viscosities may be required in other climates.
- Use only a (NGK) BR-6HS spark plug. Gap the plug to 0.028 to 0.031 in. (0.7 to 0.8 mm) Always use a spark plug wrench.

DAILY

1. Check engine oil level, and fill as necessary.
2. Check gasoline level, and fill as necessary.



Always follow the fueling procedure outlined earlier in this manual.

FIRST 20 HOURS

- Change engine oil.

EVERY 100 HOURS

- Change engine oil.
- Clean the sediment cup.
- Clean and re-gap the spark plug.
- Clean the spark arrestor.

WEEKLY

- Remove the air filter cover and clean the element. In very dusty environments, check the filter daily. Replace the element as needed. Replacement elements can be purchased from your local engine manufacturer dealer.

ENGINE OPERATION AND SERVICE

- Clean and oil air filter pad on gasoline engine every 25 hours or once weekly. Do not permit the air intake screen around the fly wheel of the gas engine to load up with paint or trash. Clean it regularly. The service life and efficiency of the gas engine model depends upon keeping the gasoline engine running properly. Change the oil in the engine every 100 hours. Failure to observe this may result in engine overheating. Consult the engine manufacturer's service manual provided.
- To conserve fuel, service life, and efficiency of the sprayer, always operate the gasoline engine at the lowest RPM at which it runs smoothly without laboring and delivers the amount required for the particular painting operation. Higher RPM does not produce higher working pressure.
- The warranty on gasoline engines or electric motors is limited to the original manufacturer.

7.4 TYPICAL WEAR PARTS

Despite the use of high-quality materials the highly abrasive effect of the paints means that wear can occur at the following parts:

INLET VALVE (spare part Order No.: 2411377)

For replacing refer to Section 8.2.

(failure becomes noticeable through performance loss and/or poor or no suction)

OUTLET VALVE (spare part Order No.: 2413371)

For replacing refer to Section 8.3.

VALVE REPAIR KIT: (spare part Order No.: 2419852, (includes the inlet and outlet valves

- Contact Titan Technical Service (1-800-526-5362) or local Titan Authorized Service Center to order repair kits.

7.4 TROUBLESHOOTING

Type of malfunction	What else?	Possible cause	Measures for eliminating the malfunction
Unit does not start		Engine out of gas	Fill engine with gas
Unit does not suck in	Air bubbles do not exit at the return hose	Inlet valve clogged	Press the inlet valve button until the stop is reached several times by hand
		Inlet/outlet valve soiled / foreign bodies drawn in / worn	Remove the valves and clean then (-> refer to Section 8.2/8.3) / replace worn parts
		Pressure control valve turned down completely	Turn the pressure control valve to the right until the stop is reached
	Air bubbles exit from the return hose	Unit is sucking in outside air	Check: Suction system tightened properly? Cleaning connection (if available) at rigid suction tube screwed tight and not leaking? Inlet valve button leaky? -> Replace wiper and O-ring (-> refer to Section 8.1
Unit does not generate pressure	Unit has sucked in air	Air in the oil circuit	Bleed the oil circuit in the unit by turning the pressure control valve completely to the left and let it run approx. 2 – 3 min. Then turn the pressure control valve to the right and set the spraying pressure (repeat process several times, if necessary).
	Unit reached pressure, but the pressure collapses during spraying.	Suction filter clogged	Check the suction filter. If necessary, clean/replace
		Paint cannot be worked in this state. Due to its properties the paint clogs the valves (inlet valve) and the delivery rate is too low.	Dilute the paint
	Unit reached pressure, but the pressure collapses during spraying.	Clogged gun filter does not let enough paint pass	Check/clean the (high-pressure filter) gun filter
		Tip clogged	Clean the tip (-> refer to Section 5.7)
	Unit does not generate the max. pressure possible. Paint nevertheless exits at the return hose.	Relief valve defective	Please contact Titan Customer Service or local Titan Authorized Service Center

8 REPAIRS



Prior to making any repairs, make sure to perform the Pressure Relief Procedure, section 5.5 of the Operating Manual P/N 2407315.

8.1 INLET VALVE PUSHER

1. Use a 17 mm wrench to screw out the inlet valve pusher (Fig. 25, item 1).
2. Replace the wiper (2) and O-ring (3).

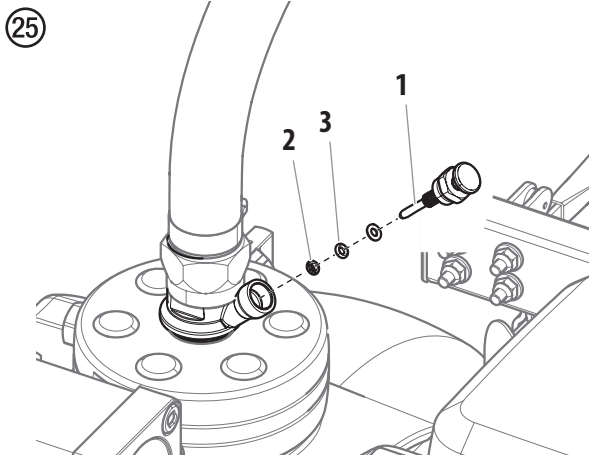

8.2 INLET VALVE

1. Place a 30 mm wrench on the housing (Fig. 26, item 1).
2. Loosen the housing (1) with light blows of a hammer on the end of the wrench.
3. Screw out the housing with the inlet valve (2) from the paint section.
4. Remove the clasp (3) using a screwdriver.
5. Place the 30 mm wrench on the inlet valve (2). Turn out the inlet valve carefully.



Never pry the valve out or damage to the housing will occur.

6. Clean the valve seat (4) with a cleaning agent and brush (ensure that no brush hairs are left behind).
7. Clean the seals (5, 6) and check for damage. Replace, if necessary.
8. Check all the valve parts for damage. In case of visible wear replace the inlet valve.

INSTALLATION

1. Insert the inlet valve (2) into the housing (1) and secure with the clasp (3). Ensure that the (black) seal (5) is mounted in the trigger housing.
2. Screw the unit from the housing and the inlet valve into the paint section. The same (black) seal (6) has to be mounted down inside the paint section.
3. Tighten the trigger housing with the 30 mm wrench and tighten with three light blows of the hammer on the end of the wrench. (Corresponds to approx. 90 Nm (67 ft.-lbs) tightening torque).

26

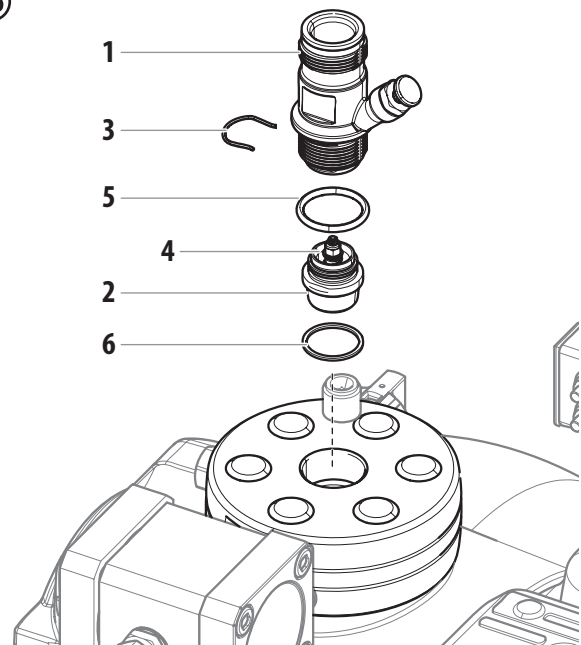

8.3 OUTLET VALVE

1. Use a 22 mm wrench to remove the outlet valve from the paint section.
2. Carefully remove the clasp (Fig. 27, pos. 1) using a screwdriver. The compression spring (2) presses ball (4) and valve seat (5) out.
3. Clean or replace the components.
4. Check the O-ring (7) for damage.
5. Check the installation position when mounting the spring support ring (3) (clipped onto spring (2)), outlet valve seat (5) and seal (6), refer to figure.

(27)

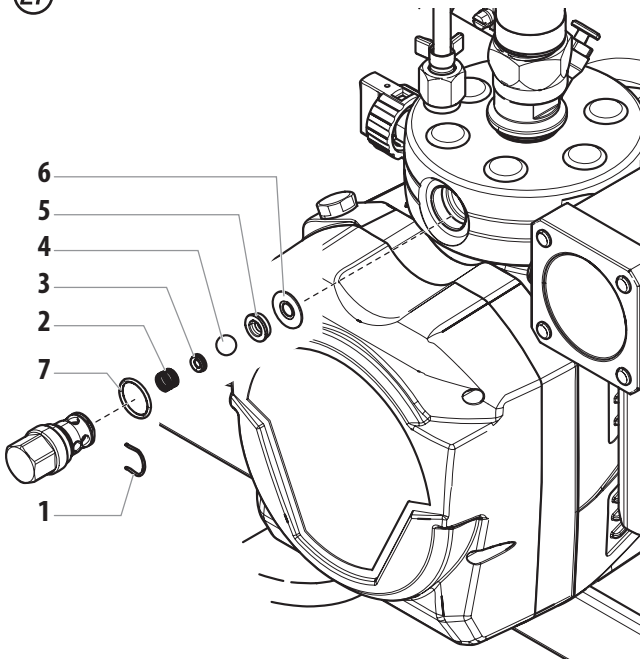

WARRANTY

Titan Tool, Inc., ("Titan") warrants that at the time of delivery to the original purchaser for use ("End User"), the equipment covered by this warranty is free from defects in material and workmanship. With the exception of any special, limited, or extended warranty published by Titan, Titan's obligation under this warranty is limited to replacing or repairing without charge those parts which, to Titan's reasonable satisfaction, are shown to be defective within twelve (12) months after sale to the End User. This warranty applies only when the unit is installed and operated in accordance with the recommendations and instructions of Titan.

This warranty does not apply in the case of damage or wear caused by abrasion, corrosion or misuse, negligence, accident, faulty installation, substitution of non-Titan component parts, or tampering with the unit in a manner to impair normal operation.

Defective parts are to be returned to an authorized Titan sales/service outlet. All transportation charges, including return to the factory, if necessary, are to be borne and prepaid by the End User. Repaired or replaced equipment will be returned to the End User transportation prepaid.

THERE IS NO OTHER EXPRESS WARRANTY. TITAN HEREBY DISCLAIMS ANY AND ALL IMPLIED WARRANTIES INCLUDING, BUT NOT LIMITED TO, THOSE OF MERCHANTABILITY AND FITNESS FOR A PARTICULAR PURPOSE, TO THE EXTENT PERMITTED BY LAW. THE DURATION OF ANY IMPLIED WARRANTIES WHICH CANNOT BE DISCLAIMED IS LIMITED TO THE TIME PERIOD SPECIFIED IN THE EXPRESS WARRANTY. IN NO CASE SHALL TITAN LIABILITY EXCEED THE AMOUNT OF THE PURCHASE PRICE. LIABILITY FOR CONSEQUENTIAL, INCIDENTAL OR SPECIAL DAMAGES UNDER ANY AND ALL WARRANTIES IS EXCLUDED TO THE EXTENT PERMITTED BY LAW.

TITAN MAKES NO WARRANTY AND DISCLAIMS ALL IMPLIED WARRANTIES OF MERCHANTABILITY AND FITNESS FOR A PARTICULAR PURPOSE WITH RESPECT TO ACCESSORIES, EQUIPMENT, MATERIALS OR COMPONENTS SOLD BUT NOT MANUFACTURED BY TITAN. THOSE ITEMS SOLD, BUT NOT MANUFACTURED BY TITAN (SUCH AS GAS ENGINES, SWITCHES, HOSES, ETC.) ARE SUBJECT TO THE WARRANTY, IF ANY, OF THEIR MANUFACTURER. TITAN WILL PROVIDE THE PURCHASER WITH REASONABLE ASSISTANCE IN MAKING ANY CLAIM FOR BREACH OF THESE WARRANTIES.

- EN -

Note on disposal:

In observance of the European Directive 2012/19/EU on waste electrical and electronic equipment and implementation in accordance with national law, this product is not to be disposed of together with household waste material but must be recycled in an environmentally friendly way!



Titan or one of our dealers will take back your used Titan waste electrical or electronic equipment and will dispose of it for you in an environmentally friendly way. Please ask your local Titan service centre or dealer for details or contact us direct.

EU Declaration of Conformity

We declare under sole responsibility that this product conforms to the following relevant stipulations:
2006/42/EC, 2011/65/EU

Applied harmonised norms:
EN ISO 12100:2010, EN 1953:2013

The EU declaration of conformity is enclosed with the product.
If required, it can be re-ordered using order number **2424151**.

EN SPRAY GUN POSITIONS

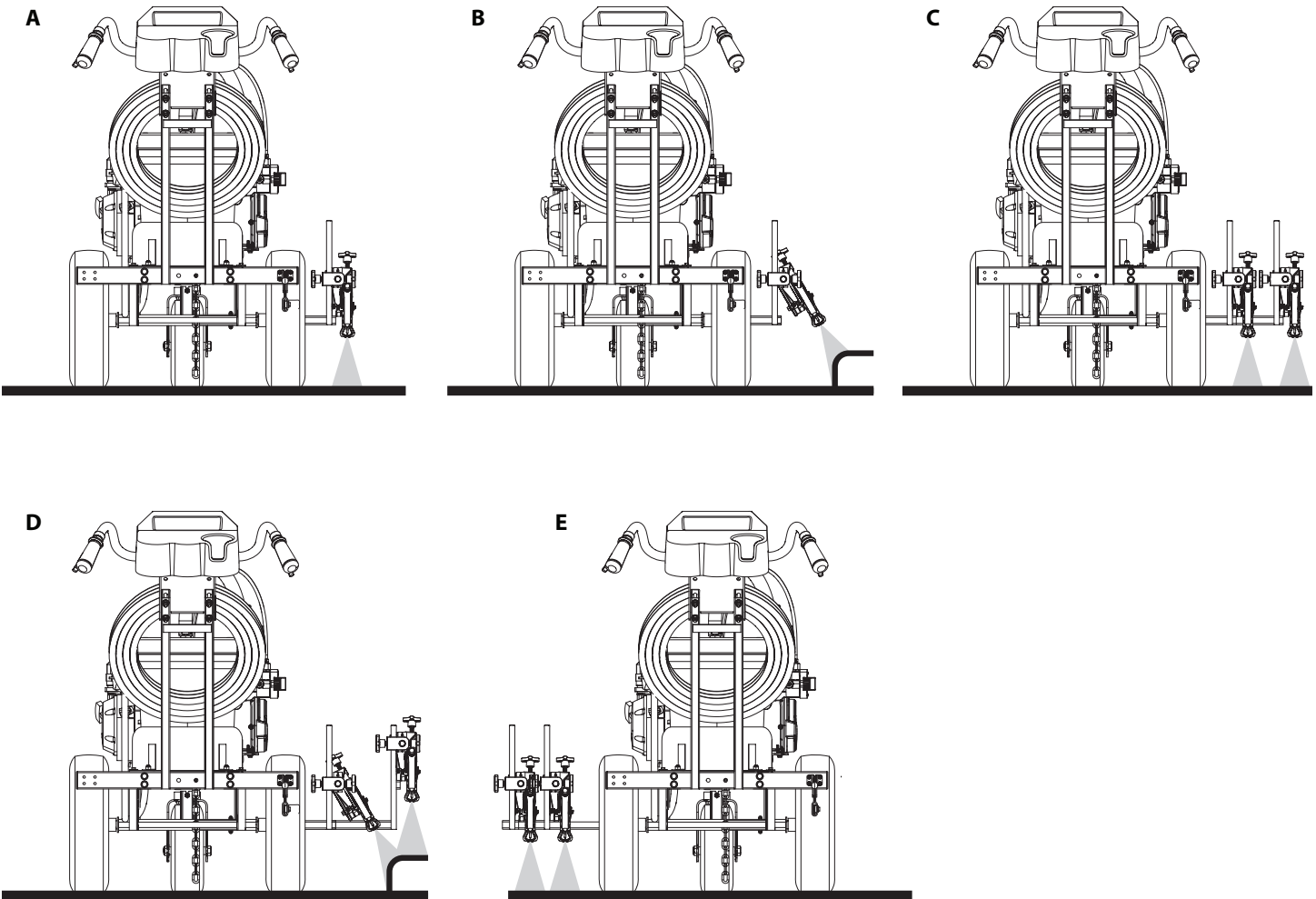

A	Single line
B	One gun curb
C	Two lines (2-gun only)
D	Two gun curb (2-gun only)
E	Two lines or one wide line (2-gun only)

EN STRIPING TIPS

EN

Titan's line striping tips provide razor sharp line edges, consistent line width, and uniform film thickness. They also reduce wasted paint and increase striper profits.

Select tips by their orifice size and fan (line) width. Determine the desired fan (line) width for the job and then the orifice size that will supply the necessary amount of fluid for proper atomization. For light viscosity fluids, use smaller orifice tips. For heavier viscosity materials, larger orifice tips are preferred.

UNDERSTANDING STRIPING TIPS

Example A: With the same fan (line) width, a larger orifice applies a greater volume of paint to the area.

Example B: With the same orifice size positioned 6" above the surface, a larger fan (line) width means the same paint amount is being applied to a greater area.

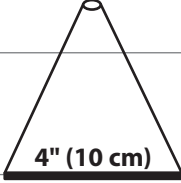
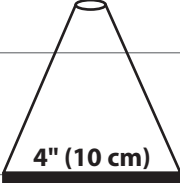
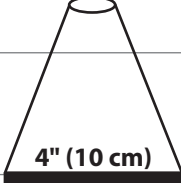
EXAMPLE A			
Tip Number	419	423	429
Orifice size	.019	.023	.029
Fan (line) width			
Film thickness	Least		Most

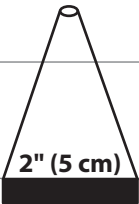
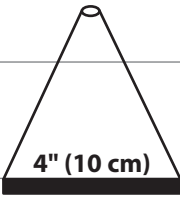
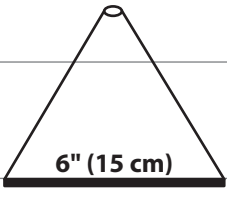
EXAMPLE B			
Tip Number	219	419	619
Orifice size	.019	.019	.019
Fan (line) width			
Film thickness	Most		Least

RECOMMENDED TIP SIZES FOR COMMON APPLICATIONS

Orifice Size Range (inches)	Application	Gun Filter (mesh)	Pump Manifold Filter (mesh)
0.013" – 0.017"	Stencil and athletic field lines	Medium	Medium
0.017" – 0.035"	Standard traffic paints	Medium	Medium
0.025" – 0.043"	Self-propelled driver (med/high speed)	Coarse	Coarse
0.039" – 0.043"	Highly viscous traffic paints	Coarse	Coarse

NOTE: Consult with your coating's technical datasheet for filter and tip size suggestions.

EN STRIPING TIP CHART

EN

EASY-TO-UNDERSTAND TIP SIZES

- Part Number: 697 – XYY
- X = Width of stripe (inches) when sprayed 6" from surface
- YY = Orifice size in thousandths of an inch
- Example: 419 = 4" wide stripe with a 0.019" orifice

		ORIFICE SIZE (INCHES)									
FAN PATTERN WIDTH	INCHES	MM	0.013	0.015	0.017	0.019	0.021	0.023	0.025	0.027	
	2	51		215	217	219					
	4	102	413	415	417	419	421	423		427	
	6	152		615	617	619	621				
	8-10	203-254					821	823			
	Flow (GPM)			0.18	0.24	0.31	0.39	0.47	0.57	0.67	0.78
	Flow (LPM)			0.68	0.91	1.17	1.47	1.78	2.15	2.53	2.95

EN ACCESSORIES

PART NO.	DESCRIPTION	
SPRAY GUNS		
538005	RX-80™ 4 finger with 517 Tip	
538006	RX-80™ 2 finger with 517 Tip	
550060	S-3 with 517 Tip	
SPRAY TIPS AND ACCESSORIES		
697-xxx	Striping tip*	
0289228A	No Build Tip Guard	
538029	Tip Swivel	
661-020	Tip seat and seal kit (5 pack)	
FILTERS		
89957	Coarse Mesh Filter (Green)	
0089958B	Medium Mesh Filter (White)	
0089959A	Fine Mesh Filter (Yellow)	
89960	Extra Fine Mesh Filter (Red)	
LINE STRIPER ACCESSORIES		
759-130	Paint Hopper (12 gallons)	
0290175A	LineSite laser	
759-150	Side Striper	
424-826	Bead Dispenser, 1-Gun Kit w/Hopper, 4–6" line width	
424-816	Bead Dispenser, 2nd-Gun Kit, 4–6" line width	
424-836	Bead Dispenser, 2-Gun Kit w/Hopper, 4–6" line width	
424-840	Bead Dispenser, 1-Gun Kit w/Hopper, 12" line width	
424-841	Bead Dispenser, 2nd-Gun Kit, 12" line width	
290181	Bead Dispenser bracket kit (required for Bead Dispenser)	
537935	Ball hitch kit / Hitch bracket (required for LazyLiner™)	
0290040H	LazyLiner™ Elite	
0290041H	LazyLiner™ Pro	
0290953A	HandiBead	
290623	Spray Shield	
290932	Stencil kit 1	
290933	Stencil kit 2	
290934	Stencil kit 3	
LUBRICANTS AND CLEANERS		
314-482	Liquid Shield™, 1 Quart	
508071	Paint Mate, 1 Quart	

* Go to www.titantool.com for tip sizes



TITAN[®]

POWRLINER[™]
4500

PERMASTROKE TECHNOLOGY[™]

Hydraulic Fluid Displacement Pump System Inside

UNITED STATES SALES & SERVICE

WEB: www.titantool.com

PHONE: 1-800-526-5362

1770 Fernbrook Lane

Minneapolis, MN 55447

INTERNATIONAL

WEB: www.titantool-international.com